

# AFMETINGEN

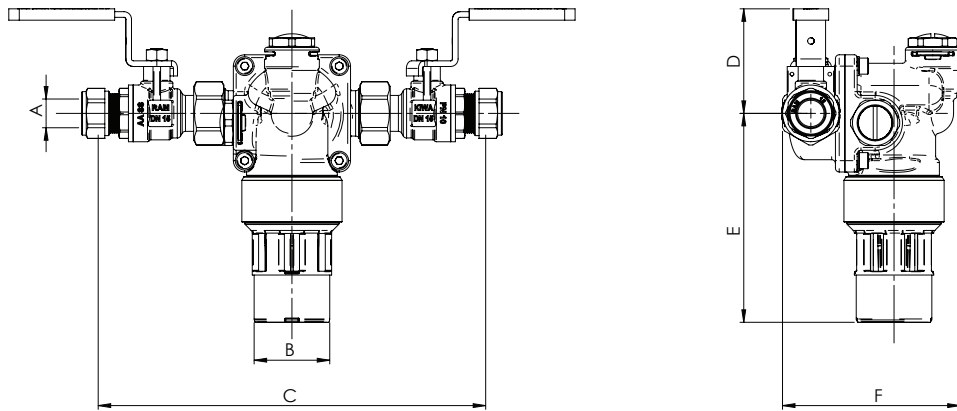

Code	DN	A	B [mm]	C [mm]	D [mm]	E [mm]	F [mm]
29.0051	15	15x15 mm knel	40	205	56	110	94
29.0052	15	22x22 mm knel	40	208	56	110	94
29.0079	15	3/4" x 3/4" bui. dr.	40	209	56	110	94
29.0075	15	15x15 mm Profipress	40	277	56	110	94
29.0076	15	22x22 mm Profipress	40	297	56	110	94
29.0077	15	15x15 mm Mapress	40	271	56	110	94