

CA-Filling-Combi 6827

with isolating valve

with permanent connection for automatic filling of unvented (pressurised) systems according to EN 1717



Field of application

The CA-Filling-Combi 6827 automatically fills and refills unvented (pressurised) systems. It is permanently connected to the potable water pipe as stipulated by EN 1717 and provides protection up to the fluid

category 3. When the supply pressure falls below the system pressure during the filling operation, the integral CA backflow preventer (class „a“) prevents the backflow of non potable water into the potable water pipe.

Design

The CA-Filling-Combi 6827 consists of a pressure reducing valve, a CA backflow preventer, an isolating valve and a drain connection. It includes

all components required to fill unvented and vented systems in conformity with European Standards.

CA-Filling-Combi 6827

with isolating valve

Materials

The body is made of dezincification-resistant brass. The diaphragm is reinforced by means of polyamide. The springs are made of corrosion protected spring steel wire, all other parts of stainless steel or dezinci-

fication-resistant brass. The stainless steel strainer has a mesh width of 0.25 mm. All synthetic parts getting into contact with water comply with the recommendations of the German Health Office (KTW).

Installation

The CA-Filling-Combi is permanently connected to the unvented system. Free access to the device must be provided permanently and it shall not be installed in locations liable to flooding or frost. The connected drain device must be able to collect the

drained volume. The connection of a hose is no longer needed to fill the system. When connecting the filling device, observe EN 1717. We recommend to install a drinking water filter upstream in order to ensure durable functionality of the valve.

Thoroughly rinse the pipe prior to installation. Install the CA-Filling-Combi in the system under consideration of the direction of flow and without applying stresses. Make

sure that the tundish faces downwards. When installing the connection line, ensure that water cannot stagnate.

Technical specifications

Connection size:	DN 15
Inlet pressure:	max. 10 bar
Outlet pressure:	1.5 – 4 bar
Factory setting:	1.5 bar (system pressure)
Medium:	Potable water
Filling capacity:	1,3 m ³ /h at 1,5 bar Δp
Service temperature:	max. 30 °C (inlet) max. 80 °C (outlet)
Mounting position:	Horizontal, tundish facing downwards
Serial number:	6827 ...

Maintenance

The pressure has to be set at static pressure. For doing so, loosen the safety screw in the adjustment handle. The requested pressure is set with a flick of the wrist. With the well-contrived combined adjustment-display handle, the pressure reducer not only ensures an optimal pressure but also allows to read the set pressure without an

additional pressure gauge. To reduce the outlet pressure, turn the adjustment handle in the direction of the minus symbol (-), to increase it, turn the adjustment handle in the direction of the plus symbol (+). It is recommended to carry out maintenance works on a regular basis to ensure a durable function.

CA-Filling-Combi
6827

with isolating valve

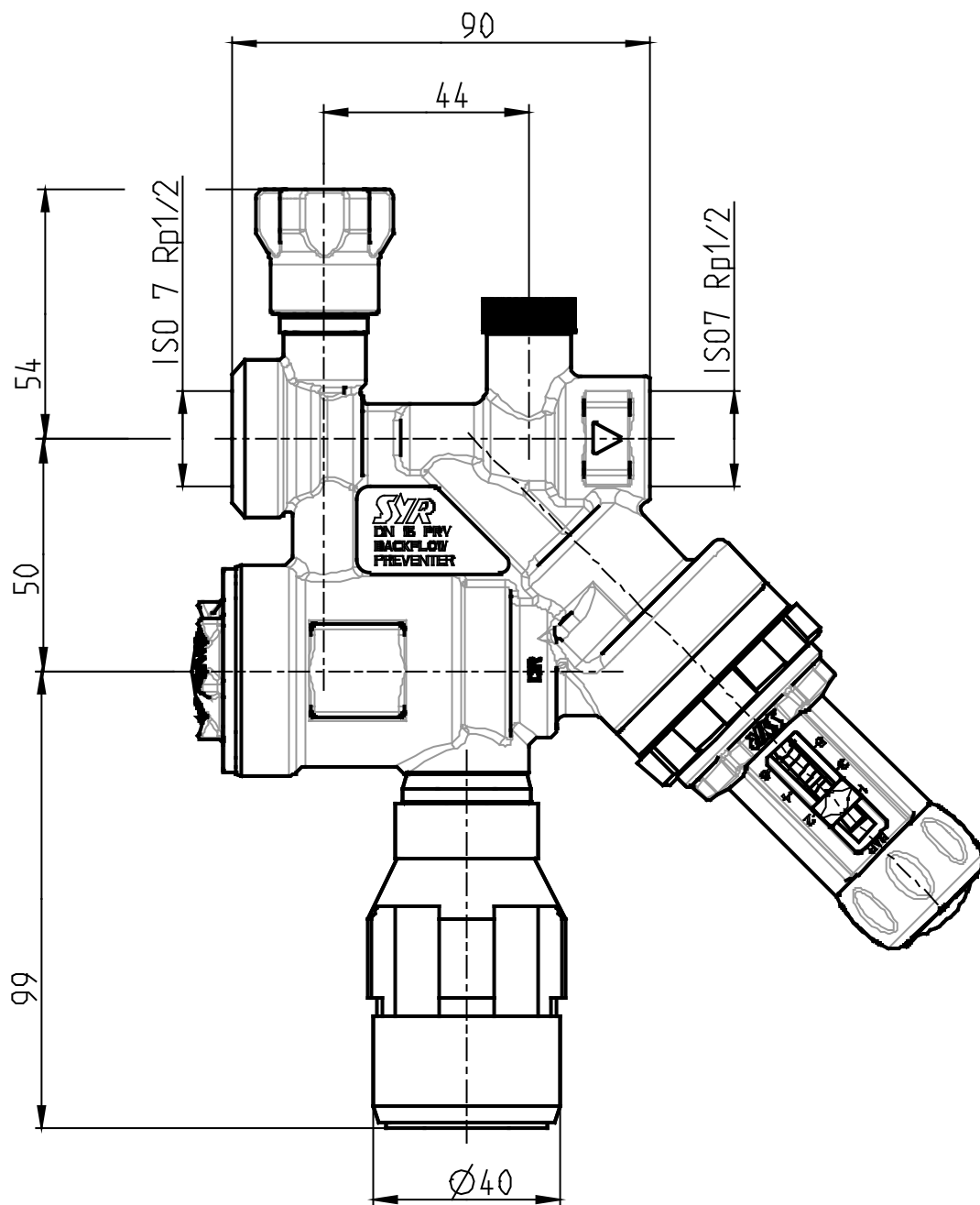

CA-Filling-Combi 6827

with isolating valve

Components / Order numbers

- ① Full cartridge
Pressure reducing valve
- ② gauge port plug
- ③ Isolating valve
- ④ Body
- ⑤ Additional check valve
- ⑥ CA cartridge - strainer integrated
- ⑦ Tundish

