

# Mounting and operating instructions

## multidata S1 Compact

# ZENNER®

### Electronic heat meter using microprocessor technology

#### Technical data

Before installing the heat meter, compare the meter's technical data with the heating system's design data. The maximum permissible load is printed on the nameplate and given as a nominal flow rate  $Q_n$  in  $m^3/h$ . For example: a meter with the specification  $Q_n$  1.5 can be loaded with maximum 1,5  $m^3/h$  resp. 1500 l/h.

#### Certification

The year of first certification resp. calibration is shown on the cover of the heat computer. The calibration is valid for 5 years.

#### Operational check

The microprocessor-controlled heat computer provides all the information about your system. You can also have the functions displayed separately. Malfunctions and installation errors are indicated by an error code on the display. An error code table comes with every meter. With the system running, ensure that the  $m^3$  display switches through and that the temperatures are approximately in accordance with the plug-in thermometers (measuring cycle: max. 2 min). Your fitter or meter reading service must send us an acceptance protocol in order to extend the term of guarantee (See the guarantee card enclosed).

#### Fitting the heat meter S1 Compact

Do not fit the meter into the return flow pipe until all installation work has been completed and the system has been rinsed. Pay attention to the direction of flow (see arrow on casing). For metrological reasons the fitting position of the meter should be the same within one system.

- Seal in front of and behind the manifold adaptor.
- Screw out the overflow cap (SW 22).
- Remove the profile gasket.
- Cleanse fit in the manifold adaptor.
- Insert new or cleansed gasket (flat side up).
- Screw in Multidata S1 Compact, tighten well with a hook wrench.
- Rotate heat computer to convenient position.
- Conduct an operational check.

#### Fitting the temperature sensor

The temperature sensors are color-coded. The nameplate is either in red or blue or has red or blue markings on it (red=forward-flow, blue=return-flow). If there is no color code on the sensor, then the sensor can be fitted in any position, but related pairs must have the same serial number. The temperature sensors resp. sleeves must be immersed sufficiently deep into the pipe. Please use only the parts originally supplied and do not install sleeves with additional extensions. **Do not shorten or lengthen sensor connection cables!**

#### User protection

For protection against unauthorized removal or manipulation seal the heat meter, as well as the temperature sensors and the volumetric measuring unit (capsule) with the seals supplied. (see drawing)

#### Important information for the fitting of heat meters

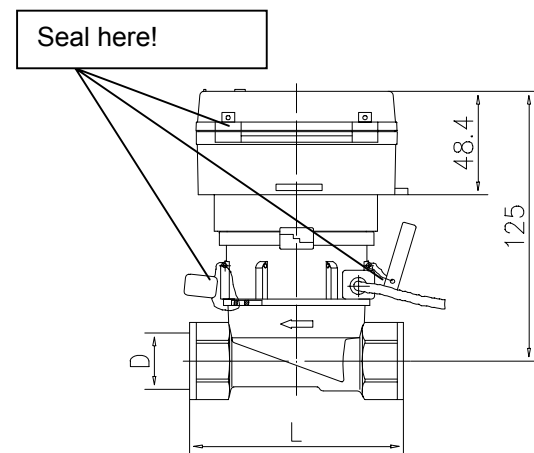

- Use the sealing material supplied.
- Mount meter principally in the return-flow.
- Arrange for shutoff valves in front of and behind the meter.
- Install sleeves resp. temperature sensors against or perpendicular to the flow direction. Insulate installation site.
- Install forward-flow and return-flow sensors in the same circulation section. Do not shorten or lengthen cables.
- Opening the shutoff valve before installing the sensor can lead to error messages (pressing the INFO-key for several seconds deletes the error message in the display).
- Minimum distance between signal and energy cables 5 cm.
- Distance of heating meter to generators of electromagnetic interference (pumps and the like) larger than 1 m.
- Interim readings serve to secure consumption values! (consumption check).
- Make note of the start positions on the meter!

# Mounting and operating instructions

## multidata S1 Compact

# ZENNER®

### Error code table

Error		Remedy
Err 00100	Volume 1 frequency too large	Correct the system
Err 00062	Wrong temperature sensor	Check sensor and connections, and replace if necessary
Err 00063		
Err 00064		
Err 00065		
Err 00071	Sensors wrong way round	Correct the system
Err 00034	Short circuit temperature sensor return-flow	Check sensor and connections, and replace if necessary
Err 00044	Short circuit temperature sensor forward-flow	
Err 00037	Return-flow sensor interruption	
Err 00047	Forward-flow sensor interruption	
Err 000xx	Other errors in temperature measurement	
Err > 1000	Internal error	Only at service company / factory

### Menus



- Q = Total energy in kWh/MWh
- V = Water quantity volume 1 in l/m³
- 1 = Volume external meter 1 in m³
- 2 = Volume external meter 2 in m³
- Self reading code
- Segment test display
- Forward-flow temperature
- Return-flow temperature
- Temperature difference
- m³/h = current flow rate
- W = current energy consumption
- h = hours operating

#### Basic setting:

#### Use:

#### Service-Program:

#### Control:

#### Error display:

Display kWh (MWh) or error (Err...)

Pressing the „Info“ key, switches the menu according to the diagram above. After a few moments the basic setting is again displayed.

Service technicians and meter-reading companies can reach other menu levels, for example, test day. Ask our factory for information sheets about this.

A turbine symbol \* (asterisk) in the upper left hand corner of the LCD-display appears with every pulse from the volumetric measuring unit and can be used as a functional check.

If there are error messages, these appear in front of the energy display until the error is corrected. Pressing the „Info“ key for several seconds will delete the error in the display.

### Connection terminals

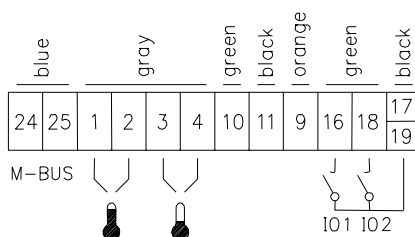

#### Attention

Only direct measuring sensors with the registration mark 22.30/84.07 (see type label) should be used when installing the return-flow sensor in the measuring capsule. No particular type resp. registration is required if forward-flow, as well as return-flow sensors are installed outside of the measuring capsule.

**Package contents:** 1 compact heat meter / 1 sealing set / 1 profile gasket for the manifold adaptor casing