

zelsius® C5-IUF

The new generation for
precise energy consumption
measurement

*Electronic compact meter for heating or cooling
energy with ultrasonic flow sensor (IUF)
Optionally with M-Bus, wM-Bus and 3 inputs/outputs
q_p 0,6/1,5/2,5 m³/h*



zelsius® C5-IUF

The new zelsius® generation

The new generation of electronic compact meter with ultrasonic flow sensor (IUF)



The zelsius® C5 ultrasonic heat and refrigeration meter operates with an innovative ultrasonic technology, specially developed for domestic energy measurement. Thanks to a combination of modern measuring technology and a very compact design, this meter is outstandingly suitable for recording all accounting data for measuring energy consumption in heating and/or refrigeration plants. The wear-free ultrasonic technology is insensible to debris, stable over the long term and is also reliable for very low volume flow rates.

The electronic calculator of the zelsius® C5 is removable as a standard and has a large, easily readable display. This is self-explanatory and, thanks to its modern additional functions, abnormal operation conditions can be identified quickly.

All important device and consumption data, such as reading date values, maximum values or the saved readings can be invoked at the touch of a button during the entire running time of the meter.

Thanks to its versatile optional communication interfaces, the zelsius® C5 guarantees cost effectiveness and ecological efficiency in consumption data recording for the future. Whether it's automated meter reading via radio or M-Bus, the zelsius® C5 provides rapid, reliable data transfer in all cases and hence guarantees customer satisfaction.

Features at a glance

- Available as heat, refrigeration or combined heat/refrigeration meter
- Lowest design height
- With optional wireless M-Bus
- With optional M-Bus
- Optionally with 3 pulse inputs or outputs
- Optionally with temperature measurement cycle of 4 seconds
- Any installation position (even "head down")
- Stores monthly readings during the whole running time
- With optional 11-year battery service life
- Precise, long-term stable, wear-free
- Very wide dynamic range
- Conforms to MID, Class 2 or 3

Technical data calculator		
Temperature range	°C	0...105 / 0...150 *
Temperature difference range	K	3...80 / 3...130 *
Display	LCD 8-digit + additional characters	
Ambient temperature during operation	°C	5...55
Storage temperature	°C	-20...+65
Resolution temperature	°C	0,01
Measurement frequency	s	Adjustable ex works, beginning with 2s, standard 30s
Unit to read the heat consumption	Standard MWh, opt. kWh, GJ	
Data storage	1 x daily	
Due date values	Storage of all monthly values during the entire operation time	
Maximum value storage	Extensive storage of flow rate, performance and other parameters	
Interface	Standard	Optical interface (ZVEI, IrDA)
	optional	M-Bus, wM-Bus, RS485, radio
Supply	3,6 V lithium battery (different capacities)	
Battery lifetime	years	>6, opt. > 11 (changeable during the operation time)
Protection class	IP54	
Environmental class acc. to EN 1434	A	
Ambient conditions/ climatic influencing (valid for complete compact meter)	- climatic	Highest permissible ambient temperature 55°C Lowest permissible ambient temperature 5°C Humidity class IP54
	- mechanical class	M1
	- electro-magnetic class	E1

* optional

Technical data temperature sensors		
Platinum precision resistor	Pt 1000	
Sensor diameter/type	mm	45 x 5,0 mm / 45 x 5,2 mm / DS 27,5 other sizes on demand
Temperature range	°C	0 ... 105 / 0 ... 150 *
Cable length	m	1,5 (opt. 5)
Installation	VL	By direct immersion or by immersion sleeves (in case of existing measuring points)
	RL	By direct immersion or by immersion sleeves (in case of existing measuring points); integrated in flow sensor, optionally external

Dimensioning limits may apply for non-symmetrical temperature sensors installation.

* optional

Technical data flow sensor						
Nominal flow, qp	m³/h	0,6	1,5	2,5		
Maximum flow qs	m³/h	1,2	3	5		
Minimum flow qi	l / h	6 / 12 / 24	15 / 30 / 60	25 / 50 / 100		
Pressure loss at qp	bar	<= 0,25 bar				
Medium temperature range*	°C	0°C <= Θ q <= 90°C / 0°C <= Θ q <= 130°C				
Minimum pressure (to avoid cavitation)	bar	1 bar at qp and 80°C medium temperature range				
Measurement accuracy class*	3 / 2					
Nominal pressure/ peak pressure	PS/PN	Body with threaded connection	16/16			
	PS/PN	Body with flange	16/16 / 25/25			
IP-Protection class	68					
Installation position	any					
Installation	Return flow, opt. forward flow					
Cable length up to calculator	m	1,2				
Installation place temperature sensors	M10 x 1					
Heat carrier	Water					
Nominal diameter	DN	15	15	20		
Connecting sizes*	Nominal flow qp [m³/h]	L [mm]	Threaded connection	Flange / ND		
			0,6	110	G3/4B	--
			0,6	130	G1B	--
		0,6	190	G1B	20	
		1,5	110	G3/4B	--	
		1,5	130	G1B	--	
		1,5	190	G1B	20	
		2,5	130	G1B	--	
		2,5	190	G1B	20	

* optional

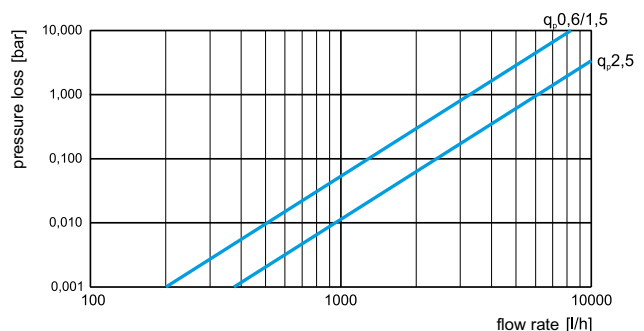

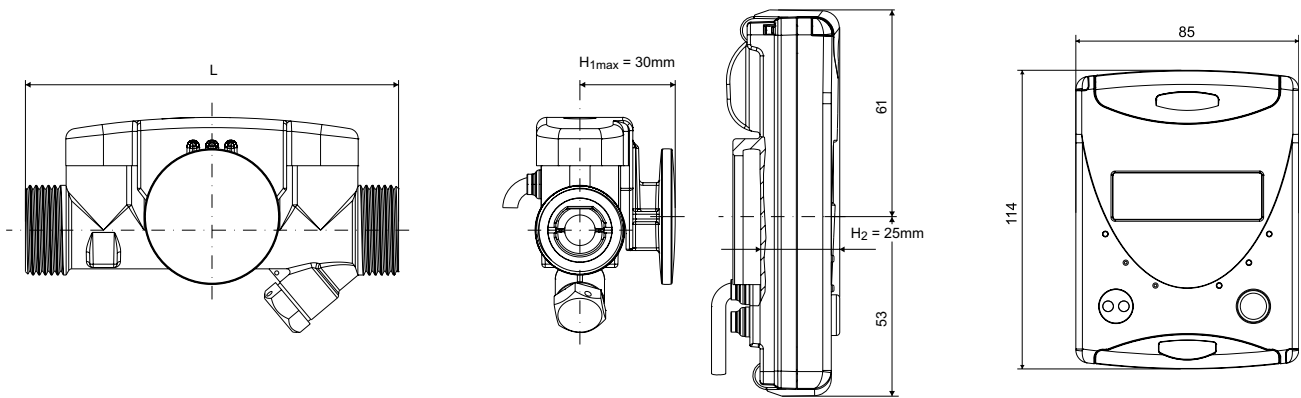

Further zelsius® C5-Versions:



zelsius® C5-CMF Compact meter with coaxial measuring capsule (CMF)



zelsius® C5-ISF Compact meter with single-jet flow sensor

ZENNER International GmbH & Co. KG

Römerstadt 6
D-66121 Saarbrücken

Telephone +49 6 81 99 676-30
Telefax +49 6 81 99 676-3100

E-Mail info@zenner.com
Internet www.zenner.com